

***Slit Lamp***  
***SL-102/203***

Instruction for use

D10S450EN  
Revision 1  
2024.02.23

## Disclaimer

Ohira will not bear any responsibilities on the following matters.

1. The trouble and/or damage caused by the results not observing the Notes on Safety or the operational method mentioned in this Instruction for use.
2. Under the circumstances not within the operating conditions of this unit including the power source or the setting environment mentioned in this Instruction for use.
3. The trouble and/or damage caused by the result(s) of remodeling or improper repair of the device.
4. When a trouble and/or damage occurs caused by the maintenance and/or repair conducted by a person other than Ohira or the dealer specified by Rexxam.
5. The trouble and/or damage of Ohira device caused by the device of other manufacturer not delivered by Ohira.
6. The trouble and/or damage caused by the maintenance and/or repair using the repair parts not specified by Ohira.
7. The trouble and/or damage caused by act of god such as fire, earthquake, flood, or thunders.

1. The contents of this Instruction for use may be changed without prior notice.
2. We have prepared the contents of this Instruction for use with thoroughgoing measures. However, if an inadequate description or error is found, please let us know.
3. It is prohibited to copy a part or an entire part of this Instruction for use without getting Ohira's permission.

# CONTENTS

1. PURPOSE OF USE.....	3
2. DEFINED INTENDED USAGE.....	3
3. INTENDED USER, PATIENT POPULATION.....	3
4. ACCESSORIES .....	3
5. INDICATIONS AND GRAPHIC SYMBOLS FOR SAFE USE .....	3
6. PRECAUTIONS FOR USE.....	5
7. WARNING DISPLAY AND POSITION .....	6
8. ASSEMBLY PROCEDURE .....	7
9. MAINTENANCE .....	8
10. SPECIFICATIONS .....	8
11. ENVIRONMENTAL CONDITIONS .....	9
12. DISCARD .....	9
13. OPERATION METHOD.....	9
14. CONNECTING TO OTHER DEVICES.....	9
15. PRODUCT STANDARD INFORMATION.....	9

# 1. Purpose of use \_\_\_\_\_

This product (SL-102/203) is a device used for observation and imaging of eyeballs, etc.

# 2. Defined intended usage \_\_\_\_\_

This product (SL-102/203) is a stereomicroscope that irradiates a transparent body such as the cornea or crystalline lens of the eyeball with interstitial light from an oblique direction to cut the light, and the light diffused by the tissue highlights slight abnormalities. Make a magnified observation by.

# 3. Intended user, patient population \_\_\_\_\_

This product (SL-102/203) is a medical electrical device. When using this product, please use it under the guidance of a doctor.

Patients undergoing medical examination with this product (SL-102/203) should follow the instructions below.

Being in a sitting position.

Being able to answer questions from doctors, optometrists, etc.

# 4. Accessories \_\_\_\_\_



Eyepiece SL-102 10X	: 2 pcs/set	Eyepiece SL-203 15X	: 2 pcs/set
Eyepiece SL-102 16X(option)	: 2 pcs/set		
Base plate	: 1 pc	Base plate fixing screw	: 4 pcs
Test bar (option for SL-102)	: 1 pc	Power supply	: 1 pc
Power cord	: 1 pc	Cap	: 1 pc
Pinion cover	: 2 pcs	Pinion cover fixing screw	: 4 pcs
Dust cover	: 1 pc	Chinrest paper	: 1 set
Hexagon wrench	: 1 pc	Instruction for use	: 1 pc

Please contact your dealer for details.



# 5. Indications and graphic symbols for safe use \_\_\_\_\_









Please read the text and follow the instructions after familiarizing yourself with the following indications and symbols.

## Display description







 Warning	Indicates a potentially hazardous situation which, if not avoided, could result in death or serious injury.
 Caution	Indicates a potentially hazardous situation which, if not avoided, may result in minor or moderate injury.
 NOTE	Useful functions to know. Paying attention to these will prevent the noted problems

## Symbol displayed on the outside of the main unit

Symbol	Description
	General warning sign
	Do not open the cover. Ask a service person for repair.

Symbol	Description
	Degree of protection against electric shock Type B Applied part
	Manufacturer
	CE mark
	Serial number
	Authorized representative in the European Community
	Medical Device
	Separate collection for waste of electrical and electronic equipment
	Consult instruction for use
	「UDI-DI」 SL-102:4571260234727 SL-203:4571260234529

**Symbol displayed on the packing box**

Symbol	Description
	Fragile, Handle with care
	This way up
	Stacking limit by number
	Keep dry
	The number on the left indicates the lower temperature limit, and the number on the right indicates the upper temperature limit.
	The number on the left indicates the lower limit humidity, and the number on the right indicates the upper limit humidity.

## 6. Precautions for use



### Warning

1. If something goes wrong (abnormal noise, smoke, etc.), immediately unplug the power cord from the outlet and contact your dealer. Continued use may cause fire or injury.
2. Connect the power cord with protective ground to a 3-core AC outlet with ground.
3. Do not disassemble, modify or repair. There is a risk of electric shock.
4. EMD electromagnetic disturbances  
This device complies with the EMD standard IEC60601-1-2: 2014, and the expected electromagnetic environment for the entire life cycle is the home healthcare environment.  
If there is electromagnetic interference stronger than the IEC 60601-1 test level, it may not be possible to irradiate gap light (slit light) as a loss / deterioration of basic performance due to electromagnetic interference.  
Do not use it near or stacked with other equipment.  
If close or stacked use is required, it is necessary to confirm normal operation in that arrangement.  
Use of accessories, transducers or cables other than those specified may result in increased emissions or reduced immunity of the product.  
Do not use equipment that generates electromagnetic waves within 30 cm (12 inch) from any part of this product. It can result in poor performance.



### Caution

1. If fingerprints, dust, etc. adhere to optical parts such as lenses, the observation image or slit image will bleed or blur, affecting the observation. Never touch it with your fingers and be careful not to get dust on it.
2. Do not install near wireless devices such as TVs and radios. There may be noise on the TV / radio.
3. If the device gets wet with liquid or foreign matter gets inside, immediately unplug the power cord from the outlet and contact the distributor.
4. Be sure to observe from the side of the instrument during observation.  
The main unit may come into contact with the eye or nose of the examinee.



### NOTE







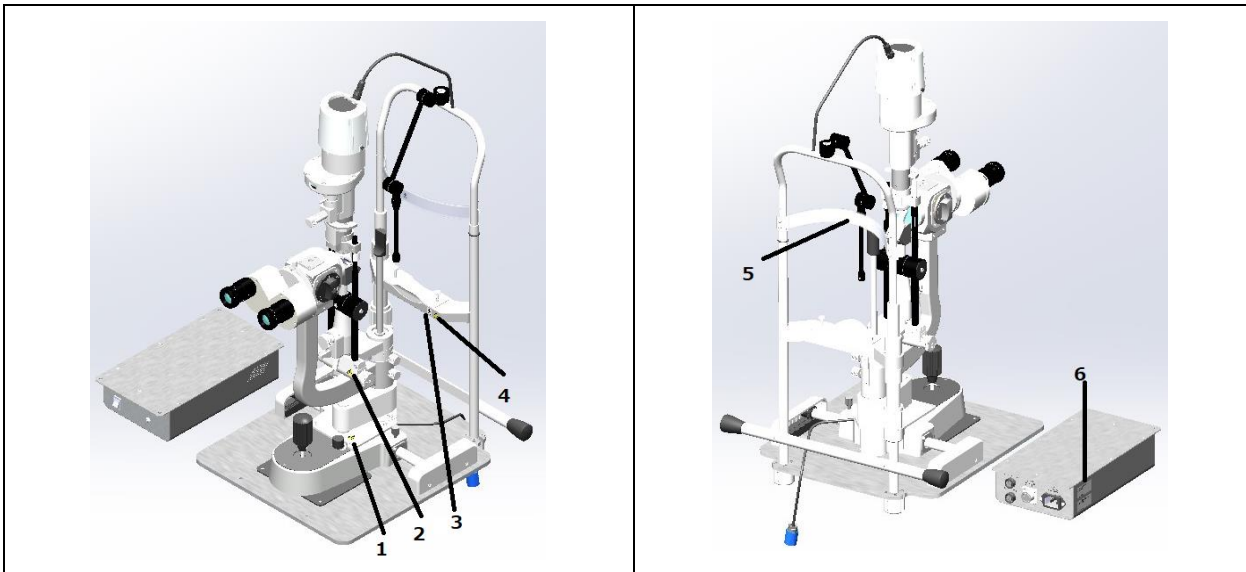

1. Report any serious accidents related to your device to the manufacturer and competent authority.

## 7. Warning display and position

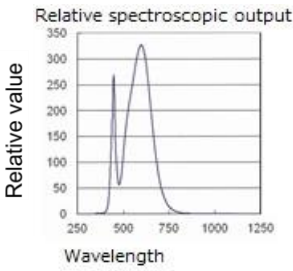
For safety reasons, warnings are indicated.

Please follow the instructions on the label to use the product properly. If the following labels are not found on the product, please contact your distributor.



No.	Label	Meaning
1		<p>Caution</p> <p>Please note the following points when operating the device.</p> <ul style="list-style-type: none"> <li>• Be careful between moving parts. There is a risk of pinching your fingers.</li> <li>• Be careful of the subject's face. The device may hit your eyes or nose.</li> </ul>
		<p>Caution</p> <p>Do not brighten the illumination light more than necessary.</p> <p>There is a potential danger to the light emitted by this device. The longer the irradiation time, the higher the risk of eye damage. When the device is operating at maximum light intensity, irradiating for more than 1 minute and 45 seconds will exceed the safety guidelines.</p> <div style="text-align: right;">  </div>
2		<p>Caution</p> <p>When changing the elevation angle of the illumination, do so slowly while supporting the device.</p> <p>Failure to do so may result in the device hitting the examinee and causing injury.</p>
3		<p>Caution</p> <p>Degree of protection against electric shock: Type B applied part.</p>
4		<p>Caution</p> <p>Maximum chinrest load: 20kg</p> <p>Do not apply force that exceeds the maximum load.</p> <p>There is a risk of damage to the chinrest and injury to the patient.</p>
5		<p>Caution</p> <p>Degree of protection against electric shock: Type B applied part.</p>
6		<p>Caution</p> <p>Do not open the cover. Ask a service person for repair.</p> <p>There is a risk of injury due to electric shock.</p>

## 8. Assembly procedure

- 1) Remove the components from the outer box.
- 2) If necessary, fix the base plate to an optical table or the like.
- 3) Align the gears on the shaft with the *rails* on the base plate and place them.

Turn the *base fixing knob* counterclockwise to unlock it, and then move the base back and forth to confirm that it moves smoothly.

Turn the *base fixing knob* clockwise to lock it, and then tighten the *screws* (two on each side) of the pinion cover to fix it.

- 4) Attach the chin stand to the base plate.  
Insert the pillar of the chin stand into the *chin stand fixing block* of the base plate, secure with screws (4 places).  
Tighten the arm bar to the pillar with *screws* (one on each side) to fix it.

- 5) Connect the lighting cable to the *lighting connector* on the power supply.

Connect the fixation light cable to the *fixation light connector* on the power supply.

Connect the *lighting control cable* to the *light control connector* on the power supply.

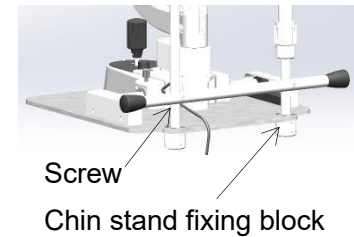
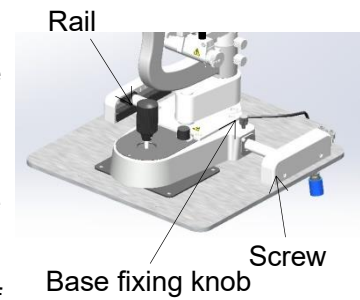

Fixation light connector      Lighting connector

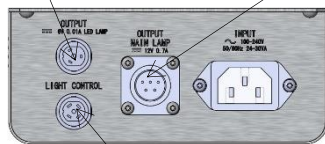

Light control connector

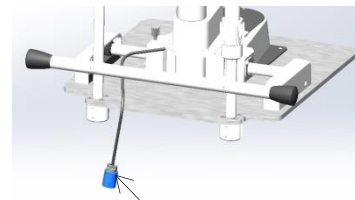

Light control cable

- 6) Connect the *lighting connector* to the *lamp house*.
- 7) Install the chinrest paper.
- 8) Connect the power cord.
- 9) Operation check
  - Turn the joystick and check that the device moves up and down.
  - Move the *joystick* and check that the device operates back and forth and left and right.
  - Turn the *chinrest up/down handle* and check that the chinrest works up and down.

Lighting connector



Lamp house

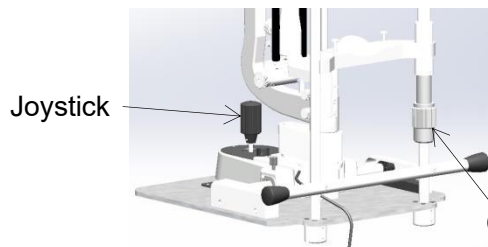

Chinrest up/down handle



## 9. Maintenance

### Periodic inspection: Check before use.

- 1) Turn the joystick and check that the device moves up and down smoothly.
- 2) Loosen the base fixing knob and check that the joystick operates back and forth and left and right.
- 3) Turn the chinrest up/down handle and check that the chinrest works.
- 4) Check the slit operation by changing the slit aperture and slit width.
- 5) Move the filter switching lever and check that the filter is switched.
- 6) Turn or switch the magnification dial of the microscope and check that the magnification changes.

### Daily care

- 1) If you do not use the device for a long time, turn off the power switch and unplug the power cord from the outlet.
- 2) If you do not use the device for a long time, lower the device to the bottom and fix the device with the base fixing knob.
- 3) When not in use, cover the device with a dust cover.
- 4) If the forehead plate or chinrest becomes soiled, wipe it with neutral detergent.  
When reusing, disinfect the forehead plate and chinrest with ethanol for disinfection.
- 5) If the cover gets dirty, wipe it dry. If the cover is heavily soiled, wipe it with a small amount of water or neutral detergent.
- 6) Fingerprints and dust on the lens and other optical components will affect observation.  
If they become dirty, wipe them off lightly using a soft cloth. In this case, handle with care to avoid scratches. If there is no recovery even after taking the necessary measures, please contact your distributor immediately.
- 7) If the sliding plate, rails, or moving shaft become dirty, move the mount section back and forth, left and right, and clean them with a dry cloth.

### Replacement of consumables

- 1) Replenishing chinrest paper  
When you run out of chinrest paper, pull out the chinrest paper pin and refill the chinrest paper.

## 10. Specifications

1. Microscope	SL-102	SL-203
(1) Type	Greenough-type	Galilean-type
(2) Total Magnification (Field of View)	10X( $\phi$ 16.4), 16X( $\phi$ 11.2), 25.6X( $\phi$ 10.2)	6.4X( $\phi$ 37), 10X( $\phi$ 23), 16X( $\phi$ 15), 25X( $\phi$ 9), 40X( $\phi$ 6)
(3) Eyepieces	10X, 16X(option)	15X
(4) Diopter Adjustment Range	$\pm 8$ [D]	$\pm 7$ [D]
(5) Pupillary Distance	55-80[mm]	50-80[mm]
2. Illumination system		
(1) Slit Width	0-15[mm] (continuous)	
(2) Slit Height	0.5-15[mm] (continuous)	
(3) Diaphragm Sizes	$\phi$ 0.2, 1, 3, 5, 8, 15 [mm]	
(4) Slit direction	Angle - Continuously variable from vertical to horizontal Elevation angle—5, 10, 15, 20 [°] from the bottom Can be swung sideways $\pm 2.5$ [°]	
(5) Filters	Switching: Cobalt blue, 50% ND, Heat absorption, Green (Red free) Regular use: UV cut	
(6) Light Source	LED	
3. Base		
(1) Depth Shift	100 [mm]	
(2) Side shift	100 [mm]	
(3) Fine movement amount	$\phi$ 20 [mm]	
(4) Height Shift	29 [mm]	
4. Chinrest		
(1) Height Shift	80 [mm]	

5. Dimension / weight	
(1) Dimension	400 [mm] (W)*305 [mm] (D)*700 [mm] (H)
(2) Weight	16.0 [kg] (SL-102), 16.5 [kg] (SL-203)
6. Rated power	
(1) Power rating	AC 100 - 240 [V], 50 / 60 [Hz]
(2) power consumption	24-30 [VA]

## 11. Environmental conditions

---

### Environmental condition of use

Temperature : 10°C to 35°C  
Humidity : 30% to 90% (No condensation)

### Storage conditions

Temperature : -10°C to 55°C  
Humidity : 10% to 95% (No condensation)

### Transport conditions

Temperature : -40°C to 70°C  
Humidity : 10% to 95% (No condensation)

## 12. Discard

---

To prevent possible damage to the environment and possible health, the device must be disposed of as follows:



- (i) For EU countries, follow the WEEE Directive or
- (ii) All other countries are subject to local disposal and recycling laws. Packing materials, accessories, etc.

Classify by material and dispose of according to the instructions of the local government.

## 13. Operation method

---

- 1) Connect each cable.
- 2) Connect the power cord to the outlet.
- 3) Turn on the power switch of the power supply.
- 4) Adjust diopter and eye width.
- 5) Place the examinee's chin on the chinrest and adjust the height so that the eye mark is aligned with the height of the eye.
- 6) Turn the magnification dial or switch the magnification lever to match the desired magnification, adjust the brightness of the illumination, slit width, filter, etc., and move the mount to observe the eye.
- 7) After completing the observation, turn off the power switch, unplug the power cord from the outlet, clean the equipment, and apply the dust cover provided.

## 14. Connecting to other devices

---

This device can be connected to the following products as optional accessories.

Connectable applanation tonometer  
SL-TM: B-44 (guide plate type), B-45 (swing arm type)

For information on how to install, clean, disinfect, use, and store the equipment, refer to the instruction manual for each connected device.

For purchase, please contact your distributor.

## 15. Product standard information

---

This product complies with ISO 10939: 2017.



Branded by

**Rexxam**

Rexxam Co., Ltd.

Eye-care Instruments Sales Dept. Tokyo Office

2-4-2 Kanda-Tsukasa-machi, Chiyoda-ku, Tokyo, 101-0048 Japan

TEL: +81-3-6262-9471

FAX: +81-3-6262-9472

E-mail: [eye@rexxam.co.jp](mailto:eye@rexxam.co.jp)

URL: <http://www.rexxam.co.jp>

Sales license number: 4501011300048

EC REP

Rexxam Co., Ltd. Netherlands Office

Steenovenweg 5, 5708HN Helmond, The Netherlands

Tel: +31 6 51939253

E-mail: [David-klooster@rexxam.co.jp](mailto:David-klooster@rexxam.co.jp)

SRN: NL-AR-000002643

CH REP

Swiss Authorised representative:

VISAVI Instruments Suisses

Chemin des Chalets 7

1279 CHAVANNES-DE-BOGIS Suisse

TEL: +41 79 332 3001

**OHIRA**



Ohira Co., Ltd.

629-961 Niiborishinden, Minamiuonuma-shi, Niigata-ken 949-7135 Japan

TEL: +81-25-775-3891

FAX: +81-25-775-3890

E-mail: [info@ohira.co.jp](mailto:info@ohira.co.jp)

URL: <http://www.ohira.co.jp>

SRN: JP-MF-000004195



**Download**

You can download "Instruction For Use" for this product at the following address.

The contents of this "Instruction for use" may be changed without prior notice.

<https://www.ohira.co.jp/instruction-for-use/>