

***Applanation Tonometer***

***SL-TM***

# Instruction for use

The electronic data of the instruction manual can be viewed on Ohira's website.

The contents of this Instruction for use maybe changed without prior notice.

D10S072EN  
Revision 0  
2022.07.08

## Disclaimer

Ohira will not bear any responsibilities on the following matters.

1. The trouble and/or damage caused by the results not observing the Notes on Safety or the operational method mentioned in this Instruction for use.
2. Under the circumstances not within the operating conditions of this unit including the power source or the setting environment mentioned in this Instruction for use.
3. The trouble and/or damage caused by the result(s) of remodeling or improper repair of the device.
4. When a trouble and/or damage occurs caused by the maintenance and/or repair conducted by a person other than Ohira or the dealer specified by Rexxam.
5. The trouble and/or damage of Ohira device caused by the device of other manufacturer not delivered by Ohira.
6. The trouble and/or damage caused by the maintenance and/or repair using the repair parts not specified by Ohira.
7. The trouble and/or damage caused by act of god such as fire, earthquake, flood, or thunders.

1. The contents of this Instruction for use may be changed without prior notice.
2. We have prepared the contents of this Instruction for use with thoroughgoing measures.  
However, if an inadequate description or error is found, please let us know.
3. It is prohibited to copy a part or an entire part of this Instruction for use without getting Ohira's permission.

## Item

1. PURPOSE OF USE.....	1
2. DEFINED AND INTENDED USE .....	1
3. INTENDED USERS, PATIENT POPULATION .....	1
4. ACCESSORY .....	1
5. INDICATIONS AND SYMBOLS FOR SAFE USE .....	1
6. PRECAUTIONS FOR USE .....	2
7. NAME OF EACH PART .....	4
8. ASSEMBLY PROCEDURE.....	5
9. MAINTENANCE.....	6
10. SPECIFICATIONS.....	8
11. GENERAL INFORMATION FOR USE .....	9
12. DISPOSAL .....	9
13. OPERATION METHOD .....	9
14. CONNECTING TO OTHER DEVICES .....	10
15. PRODUCT STANDARD INFORMATION .....	10
16. DEVICE LIFETIME.....	10

# 1. Purpose of use \_\_\_\_\_

The applanation tonometer SL-TM (hereinafter referred to as "the instrument") is a Goldmann applanation tonometer that measures the force to obtain a certain pressure area by pressing the applanation tonometer against the cornea, converts it into intraocular pressure, and provides pressure information for diagnosis.

# 2. Defined and intended use \_\_\_\_\_

This instrument uses the Goldmann applanation tonometer method and is designed to be mounted on our designated slit lamp to obtain precise IOP values.

# 3. Intended users, patient population \_\_\_\_\_

This product is a medical device. Please use this product under the guidance of a physician. Patients undergoing testing with this product (SL-TM) must follow the instructions below. Be able to answer the doctor's questions.

# 4. Accessory \_\_\_\_\_



weight measure	:1 pc.	Tonometer mounting bolts	(Attached only to B-45/C-83/C-84)
User's Manual	:1 copy		

For details, please contact your dealer.



# 5. Indications and symbols for safe use \_\_\_\_\_





Make sure you understand the following indications and symbols before you read the text and follow the instructions.

## Display Description







 Caution	Indicates a potentially hazardous situation which, if not avoided, may result in minor or moderate injury.
 NOTE	This indication is an important addition to the explanation in the text, something you should know, or a precaution to prevent problems.

## Symbols displayed on the outside of the unit

Symbol	Description.
	Manufacturer
	CE Mark
	Serial number

Symbol	Description.
	Authorized representative in the European community
	Medical Device
	Consult instruction for use
	UDI-DI" B-44: 4571260230712 B-45: 4571260230705 C-83: 4571260230729 C-84: 4571260230736

#### Symbols displayed on the packing box

symbol	Description.
	Breakage warning, broken items
	Stacking is limited by number
	be careful not to get wet
	The number on the left indicates the lower temperature limit, and the number on the right indicates the upper temperature limit
	The number on the left indicates the lower limit humidity, and the number on the right indicates the upper limit humidity
	Distributor

## 6. Precautions for use

 <b>Caution</b>
<ol style="list-style-type: none"> <li>1. This unit is a tonometer that measures intraocular pressure values and should be used only by skilled persons with expertise. Failure to do so may result in malfunction or accident.</li> <li>2. Do not directly touch the pupil contact area on the tip of the measuring prism with your finger. This will not only deteriorate the observed image but also cause infection.</li> <li>3. Use only measuring prisms that comply with ISO8612:2009.</li> <li>4. This not only prevents the correct measurement of intraocular pressure, but also causes irritation to the cornea and corneal damage.</li> <li>5. Do not use a damaged measuring prism. Not only will the observation image be poor, but it may also cause corneal damage.</li> <li>6. Disinfect the measurement prism according to the disinfection method described in "9. Maintenance: Daily Care". Incorrect disinfection method may cause infection or corneal damage.</li> <li>7. Always use disinfected measuring prisms. Use of non-disinfected measuring prisms may cause infection.</li> </ol>

 **Caution**

8. Do not modify or disassemble this unit in any way.  
Doing so may result in incorrect measurement of intraocular pressure.
9. Do not handle this instrument roughly.  
Doing so may not only cause malfunction but may also prevent correct measurement of IOP values.
10. If this unit malfunctions or an abnormality occurs, immediately contact your dealer.  
Continued use of the product in a malfunctioning condition may result in an accident.
11. Do not use this instrument except for our specified slit lamp.  
Doing so may not only result in incorrect measurement of intraocular pressure but may also cause malfunction or injury.  
  
\*Please read the precautions for the use of the Slit lamps IFU carefully.
12. Do not use or install the product in the following places.
  - 1) Locations where the ambient temperature is below 10°C or above 35°C
  - 2) Places exposed to harmful gases
  - 3) Places with high humidity
  - 4) Places exposed to steam
  - 5) Areas subject to water droplets
  - 6) Dusty or gritty places
  - 7) Locations with excessive oil vapor
  - 8) Locations exposed to salty air
  - 9) Locations with explosive gases and dust
  - 10) Locations subject to vibration and shock
  - 11) Locations exposed to direct sunlight
  - 12) Near objects that generate strong magnetic force or radio waves



**NOTE**

- 1) Report any serious incidents related to the device to the manufacturer and competent authorities.

## 7. Name of each part

- 1 Side plate
- 2 Tonometer body arm
- 3 Prism holding arm
- 4 Pressure scale drum
- 5 Pressure adjusting knob
- 6 Weight holder
- 7 Prism
- 8 Tonometer Holding base
- 9 Prism supporter
- 10 Screw
- 11 weight
- 12 Peg

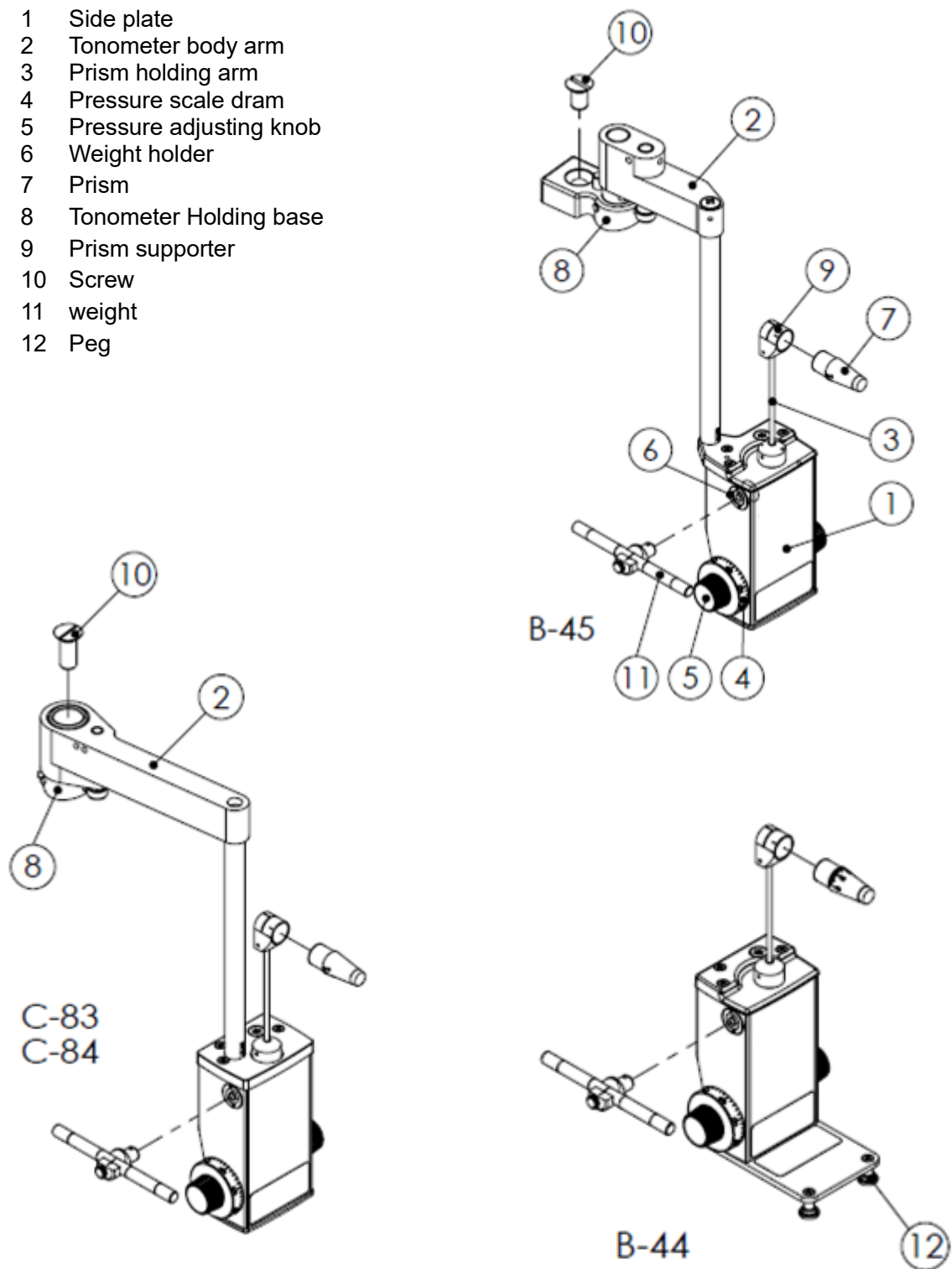

Figure-1.

## 8. Assembly Procedure

---

1. Remove the SL-TM main unit, mounting bolts, etc. from the box.
2. Mounting method on slit lamp
  - 1) In the case of B-45/C-83/C-84, firmly attach the Tonometer holding base (8) to the top of the microscope of the slit lamp with the tonometer mounting screw (10) (Fig. 2: B-45), insert the Tonometer body arm (2) into the Tonometer holding base (8), and confirm that it is held in the V-groove in the center of the Tonometer holding base (8) (Fig. 3: B-45).
  - 2) In the case of B-44, place it on the slit lamp guide plate and set it to the fixed position using the peg 12. (Fig. 4:B-44)



Figure-2.



Figure-3.



Figure-4.

### 3. Preparing the tonometer

- 1) Correctly attach the disinfected prism (7) to the prism supporter (9).
- 2) If there is no corneal astigmatism, align the 0° and 180° of the prism (7) with the horizontal graduation line (white line) of the prism supporter (9) (Figure-5).
- 3) In the case of strong corneal astigmatism (3D or greater), align the scale of the prism (7) corresponding to the angle of the weak main line of astigmatism with the line tilted 43° from the horizontal (red line) on the prism supporter (9).
- 4) Make sure that the tonometer is set in front of the microscope, and rotate the prism supporter (9) so that the prism (7) is correctly facing the examinee.
- 5) Turn the pressure adjusting knob (5) to set the pressure scale dram (4) to 1.



Figure-5.



## 9. Maintenance

Periodic inspection: Check before use.

### 1. Inspection of measured values

You can check if the measurements are accurate by using the weight (11), which is included in the kit.

Attach the weight (11) to the weight measure receiver (6) with the prism (7) attached to the prism supporter (9).

Attach the weight (11) to the weight measure receiver (6). By changing the fixing position of the weight (11), you can apply a load of 2g or 6g.

\* (Note that the measurement error varies depending on the fixed position of the weight (11). (Please note that the measurement error varies depending on the fixed position of the weight (11).)

Turn the pressure adjusting knob (5) slowly to check the operation.

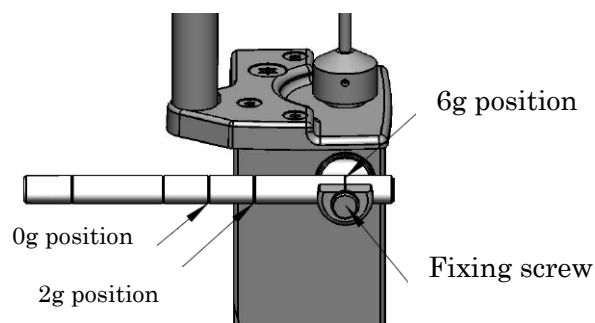

#### Confirmation of 0 mmHg

- 1) Fix the weight (11) at the 0g position.
- 2) Turn the pressure adjusting knob (5) so that the value in the pressure scale dram (4) becomes 0.
- 3) Make sure that the prism (7) collapses to the side of the examinee when the pressure adjusting knob (5) is turned to the plus side to the point where it passes the width of the scale line indication.
- 4) Make sure that the prism (7) collapses toward the examiner when the pressure adjusting knob (5) is turned to the minus side to the point where it passes the width of the scale line indication.

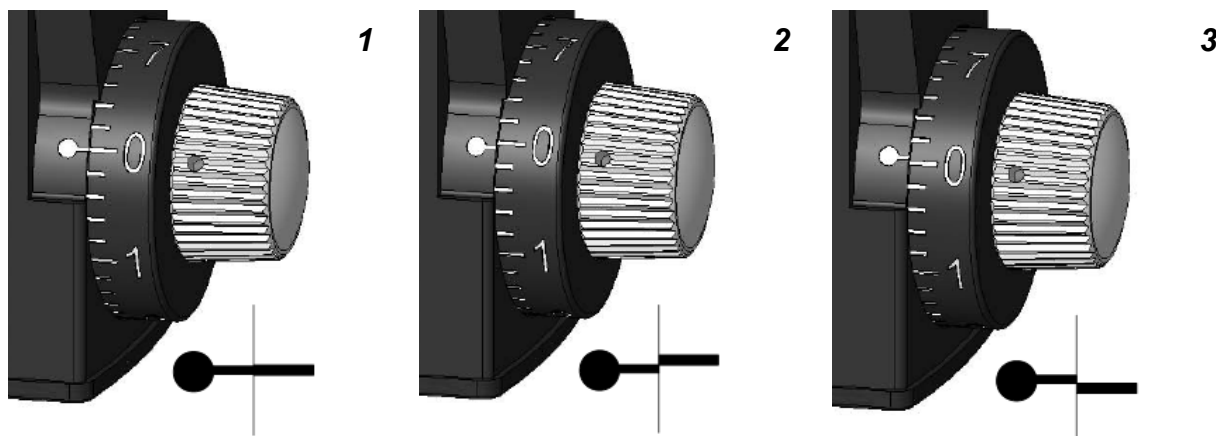

#### Confirmation of 20 mmHg

- 1) Fix the weight (11) at the 2g position.
- 2) Turn the pressure adjusting knob (5) so that the value in the pressure scale dram (4) becomes 2.
- 3) Make sure that the prism (7) collapses to the side of the examinee when the pressure adjusting knob (5) is turned to the plus side to the point where it passes the width of the scale line indication.
- 4) Make sure that the prism (7) collapses toward the examiner when the pressure adjusting knob (5) is turned to the minus side to the point where it passes the width of the scale line indication.

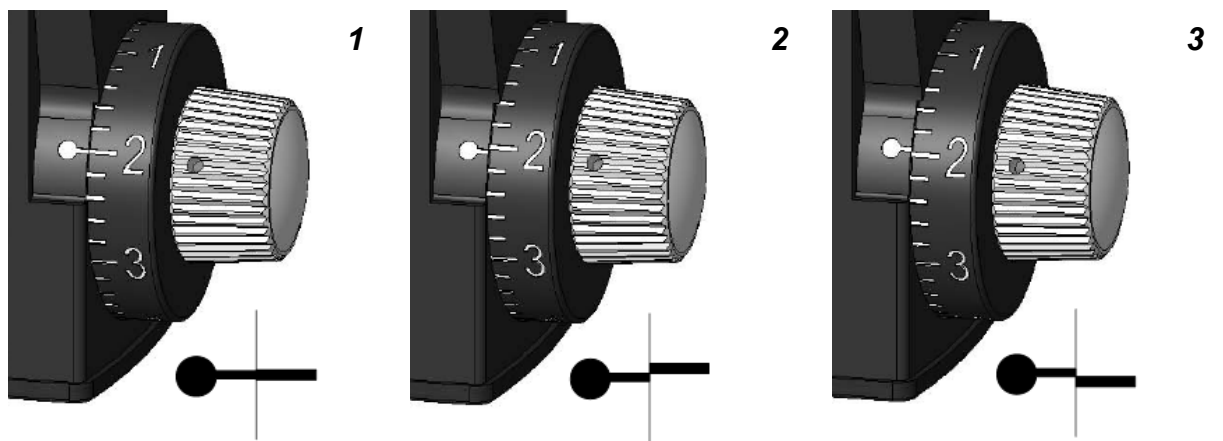

Confirmation of 60 mmHg

- 1) Fix the weight (11) at the 6g position.
- 2) Turn the pressure adjusting knob (5) so that the value in the pressure scale dram (4) becomes 6.
- 3) Make sure that the prism (11) collapses to the side of the examinee when you turn the pressure adjusting knob (5) by 1/2 turn to the positive side.
- 4) Make sure that the prism falls toward the examiner when the pressure adjusting knob (5) is turned by 1/2 turn to the minus side.

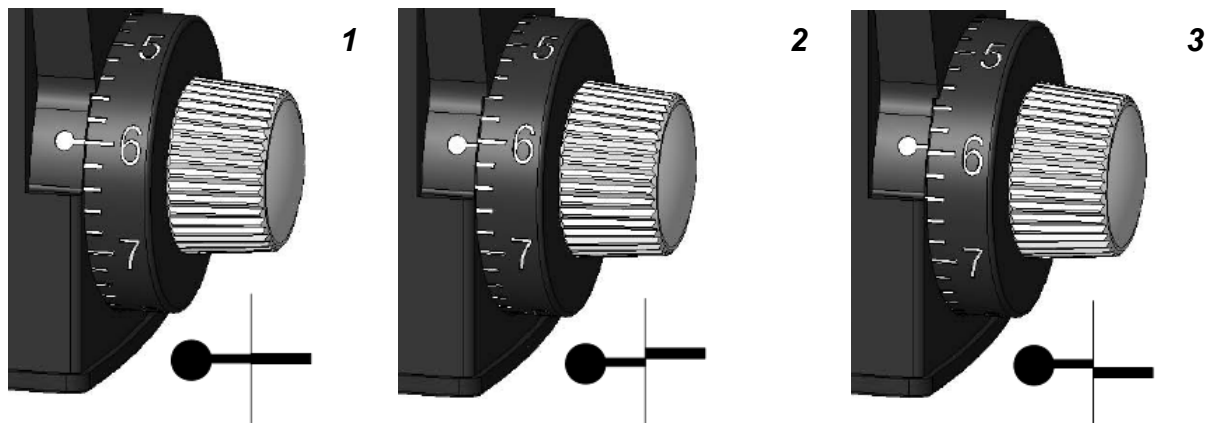

2. When you think you have a problem?  
Please re-read the instructions section.

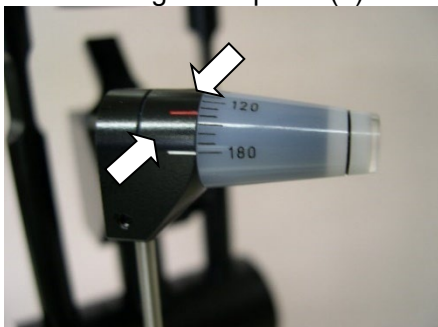

state	Support
Measurements are incorrect.	Check the measured value with the weight (11) according to "10. Inspection Procedure". If the measured value exceeds the allowable range, contact your dealer for repair or calibration.
The measuring prism is out of the center of the eyepiece field of view.	Make sure that the prism supporter (9) is facing the front correctly. If, after checking the above, it is found to be clearly out of alignment, check with your dealer on how to deal with it.
Loose fixing of measuring prism.	Pull out the prism (7) from the prism supporter (9) and squeeze the ring part of the prism supporter (9) to make the holding circle smaller and secure the fixing of the prism (7).



If the above does not solve the problem, please contact your dealer.

### 3. Daily Care

#### Cleaning and disinfection

	<b>Disinfect the prism (7) for measurement according to the disinfection method described below.</b> Do not autoclave, boil, or disinfect with highly concentrated alcohol, as this may cause damage to the prism (7).
	<b>Be sure to use a disinfected measuring prism.</b> Since the prism (7) comes in direct contact with the patient's cornea and tear fluid, be sure to disinfect the prism (7) by the following method, paying sufficient attention to the prevention and control of infection. Always use a disinfected prism (7) when the eye under test changes.

- 1) Rinse off fluorescein, etc. adhered to the prism (7) with running water for about 1 minute to clean it.
- 2) Disinfectant such as Hibiten alcohol containing 0.5% chlorhexidine gluconate for about 10 minutes
- 3) Immerse the prism in the disinfectant. Stir occasionally, as the measuring prism will float in the disinfectant and the parts not immersed will not be disinfected.  
Follow the instruction manual of the medicine for handling the disinfectant.
- 4) Rinse off the disinfectant with clean water; 10 to 20 minutes is recommended.
- 5) Wipe off any moisture with a clean, dry, soft cloth or paper.
- 6) Store the product in a clean storage box or other container to prevent it from being exposed to dust and dirt.
- 7) When cleaning the tonometer and other parts, avoid using organic solvents (thinner, ether, alcohol, etc.) on plastic parts or painted parts.

### 4. Replacement of consumables

#### Prism

Use a prism that conforms to ISO8612 standards.

## 10. Specifications

1. Body part	
1) Measurement method	horizontal type
2) Measurement range	0 ~ 80 mmHg (0 ~ 78.4 mN)
3) Minimum scale	2 mmHg (1.96 mN)
4) Measurement of intraocular pressure	Nominal value $\pm 1.5\%$ or $\pm 0.5$ mmHg, whichever is greater
2. Measuring prism (Available measuring prisms) * Not included with this instrument.	
1) Mass	1.65g
2) Measurement range	methacrylic resin
3) Diameter of pressure plane	7.2 mm
4) Diameter of piezoelectric circle	3.06 mm
3. Dimensions and weight	
1) Dimensions	B-44 : 84 mm (W) 79 mm (D) 184 mm (H) B-45 : 84 mm (W) 146.4 mm (D) 249 mm (H) C-83 : 84 mm (W) 142 mm (D) 239.5 mm (H) C-84 : 84 mm (W) 142 mm (D) 241 mm (H)
2) Mass	B-44 :440g, C-45 :650g C-83 :660g C-84 :660g

## 11. General Information for Use

---

### Environmental condition of use

Temperature : 10°C to 35°C

Humidity : 30% to 90% (No condensation)

### Storage conditions

Temperature : -10°C to 55°C

Humidity : 10% to 95% (No condensation)

### Transport conditions

Temperature : -40°C to 70°C

Humidity : 10% to 95% (No condensation)

## 12. Disposal

---

In order to prevent possible damage to the environment and possible health effects, this equipment must be disposed of as follows

Comply with local disposal and recycling laws. Classify packing materials and accessories by material and dispose of them according to the instructions of the local government.

## 13. Operation Method

---

### 1. Preparing the slit lamp

- 1) Adjust the magnification of the microscope to 10x.
- 2) Make sure that the diopter adjustment of the eyepiece is correct.
- 3) In the case of B-45/C-83/C-84, swing the slit lamp lighting system to a position where the image is clear and there is little reflection.
- 4) For the B-44, swing the slit lamp illuminator to a position where the side of the prism is illuminated from about 60° lateral to the axis of the microscope.
- 5) Insert the cobalt blue filter, open the slit width fully, and turn the illumination to its brightest setting.

### 2. Operation in use

- 1) Anesthetic drops should be applied to the test eye, followed by fluorescein drops.
- 2) Fix the examinee on the slit lamp chin rest and have him gaze forward.
- 3) Carefully move the joystick lever of the slit lamp while checking the position of the eyelids and eyeballs, bring the prism (7) into contact with the central part of the cornea, and observe it through the left eyepiece.
- 4) Turn the pressure adjusting knob (5) slowly to increase the pressure, and check that the semicircular arc images in the field of view move closer to each other and touch (Figure 6-b) or overlap (Figure 6-c).

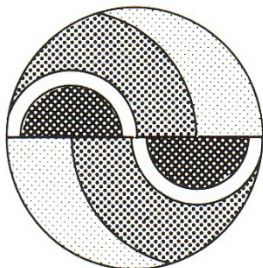

**a. Insufficient pressurization**

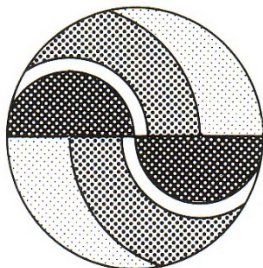

**b. Pressurization suitability**

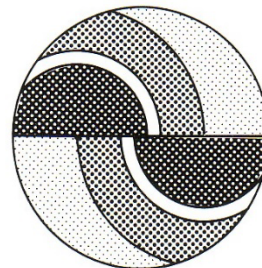

**c. Over-pressurization**

Figure-6.

- 5) Move the pressure adjusting knob (5) until the inner line of the upper left semicircular arc image matches the inner line of the lower right semicircular arc image, then stop the pressure adjusting knob (5) and gently pull the entire slit lamp away from the cornea.
  - 6) Multiply the reading from the pressure scale dram (4) by 10 to get the intraocular pressure value (mmHg).
3. Treatment after use
- 1) Remove the prism (7) from the tonometer and disinfect it.
  - 2) For the B-45/C-83/C-84, swing the tonometer to the right (or left) side and hold it.
  - 3) For B-44, remove the tonometer from the slit lamp.
  - 4) When storing the tonometer after removing it from the slit lamp, handle it with care. When storing it, make sure that it is not subjected to external pressure and that it is not covered with dust or dirt.

## 14. Connecting to other devices ---

This device is used when mounted on the following slit lamps.

Type	Slit lamp for installation
B-44	Slit Lamp SL-102/203/500 Slit Lamp RS-5000
B-45	Slit Lamp SL-95 Slit Lamp SL-102/203/500 Slit Lamp RS-500/5000
C-83	Slit Lamp SL-50
C-84	Slit Lamp SL-45/55 Slit Lamp RS-300

## 15. Product Standard Information ---

ISO 8612:2009 Ophthalmic instruments – Tonometers

## 16. Device lifetime

7 years

Distributor:

**Rexxam**



Rexxam Co., Ltd.

Eye-care Instruments Sales Dept. Tokyo Office

2-4-2 Kanda-Tsukasa-machi, Chiyoda-ku, Tokyo, 101-0048 Japan

TEL: +81-3-6262-9471

FAX: +81-3-6262-9472

E-mail: [eye@rexxam.co.jp](mailto:eye@rexxam.co.jp)

URL: <http://www.rexxam.co.jp>

Sales license number: 4501011300048

EU Authorised representative:

**Rexxam**



Rexxam Co., Ltd. Netherlands Office

Steenovenweg 5, 5708HN Helmond, The Netherlands

Tel: +31 6 51939253

E-mail: [David-klooster@rexxam.co.jp](mailto:David-klooster@rexxam.co.jp)

SRN: NL-AR-000002643

Manufacturer:

**OHIRA**



Ohira Co., Ltd.

629-961 Niiborishinden, Minamiuonuma-shi, Niigata-ken 949-7135 Japan

TEL: +81-25-775-3891

FAX: +81-25-775-3890

E-mail: [info@ohira.co.jp](mailto:info@ohira.co.jp)

URL: <http://www.ohira.co.jp>

SRN: JP-MF-000004195